

SUPPLEMENTAL POWER SUPPLY - SPS-1

OUTPUT VOLTAGE SELECTION AND BATTERY CONNECTION

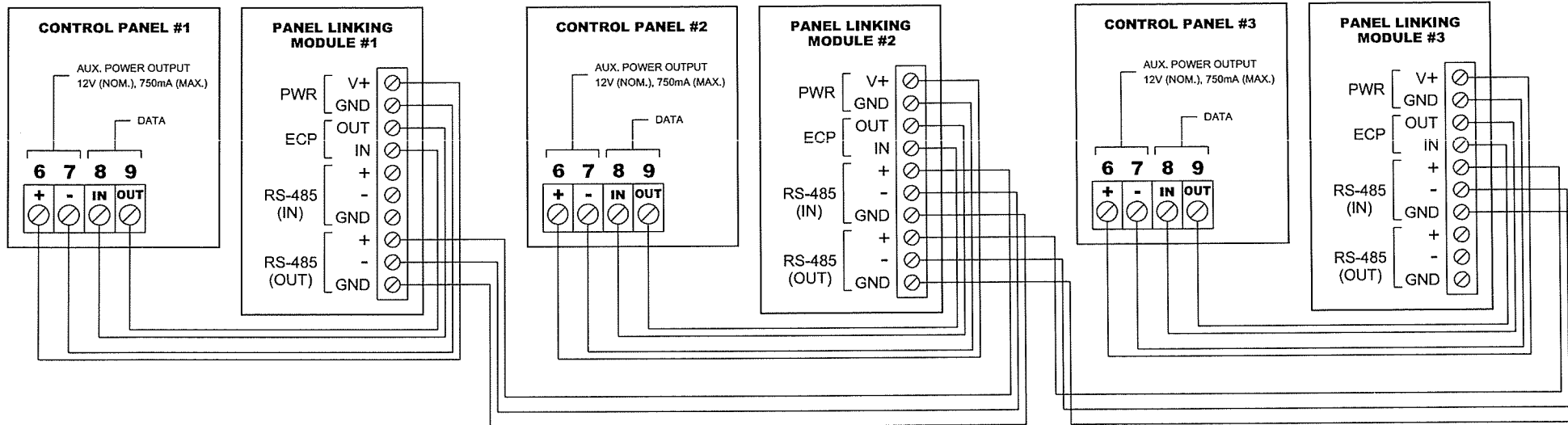



NOTES:

1. UP TO EIGHT PANEL LINKING MODULES CAN BE WIRED TOGETHER IN A DAISY CHAIN CONFIGURATION AS SHOWN ABOVE. AVOID WIRING PANEL LINKING MODULES IN A STAR CONFIGURATION WHERE MULTIPLE BRANCHES ARE FORMED.
2. THE PANEL LINKING SYSTEM REQUIRES ONE PANEL LINKING MODULE PER CONTROL PANEL. EACH PANEL LINKING MODULE DRAWS 90mA MAX. AVAILABLE ADDRESSES FOR SELECTION INSIDE THE MODULE ARE 01 TO 30 (SEE THE PANEL LINKING MODULE'S INSTALLATION INSTRUCTIONS FOR DETAILS).

PANEL LINKING MODULE SYSTEM POINT-TO-POINT CONNECTIONS - PLM-1

PANEL LINKING MODULES POWERED FROM CONTROL PANEL

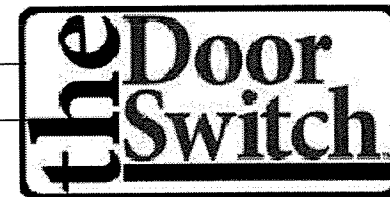

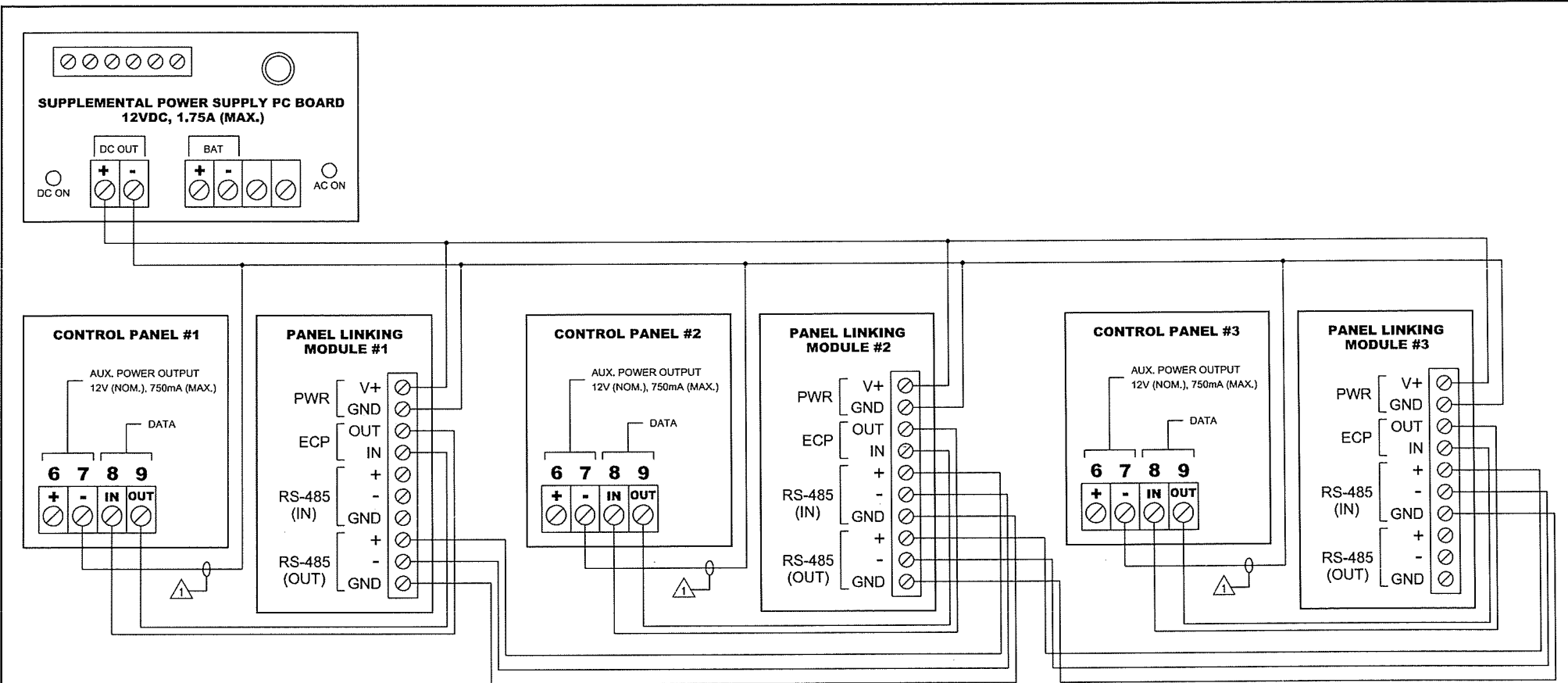

NOTES:

- 1.  IN ORDER TO PROVIDE A RETURN PATH FROM THE DATA IN/OUT TERMINALS OF EACH PANEL LINKING MODULE POWERED BY THE SUPPLEMENTAL POWER SUPPLY, A WIRE MUST BE CONNECTED BETWEEN TERMINAL 7 OF THE CONTROL PANEL AND THE NEGATIVE TERMINAL OF THE SUPPLEMENTAL POWER SUPPLY.
- 2. UP TO EIGHT PANEL LINKING MODULES CAN BE WIRED TOGETHER IN A DAISY CHAIN CONFIGURATION AS SHOWN ABOVE. AVOID WIRING PANEL LINKING MODULES IN A STAR CONFIGURATION WHERE MULTIPLE BRANCHES ARE FORMED.
- 3. THE PANEL LINKING SYSTEM REQUIRES ONE PANEL LINKING MODULE PER CONTROL PANEL.
- 4. AVAILABLE ADDRESSES FOR THE PANEL LINKING MODULE ARE 01 TO 30 (SEE THE MODULE'S INSTALLATION INSTRUCTIONS FOR DETAILS).

PANEL LINKING MODULE SYSTEM POINT-TO-POINT CONNECTIONS - PLM-2

PANEL LINKING MODULES POWERED FROM A SUPPLEMENTAL POWER SUPPLY

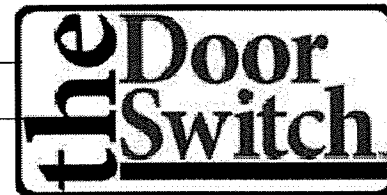

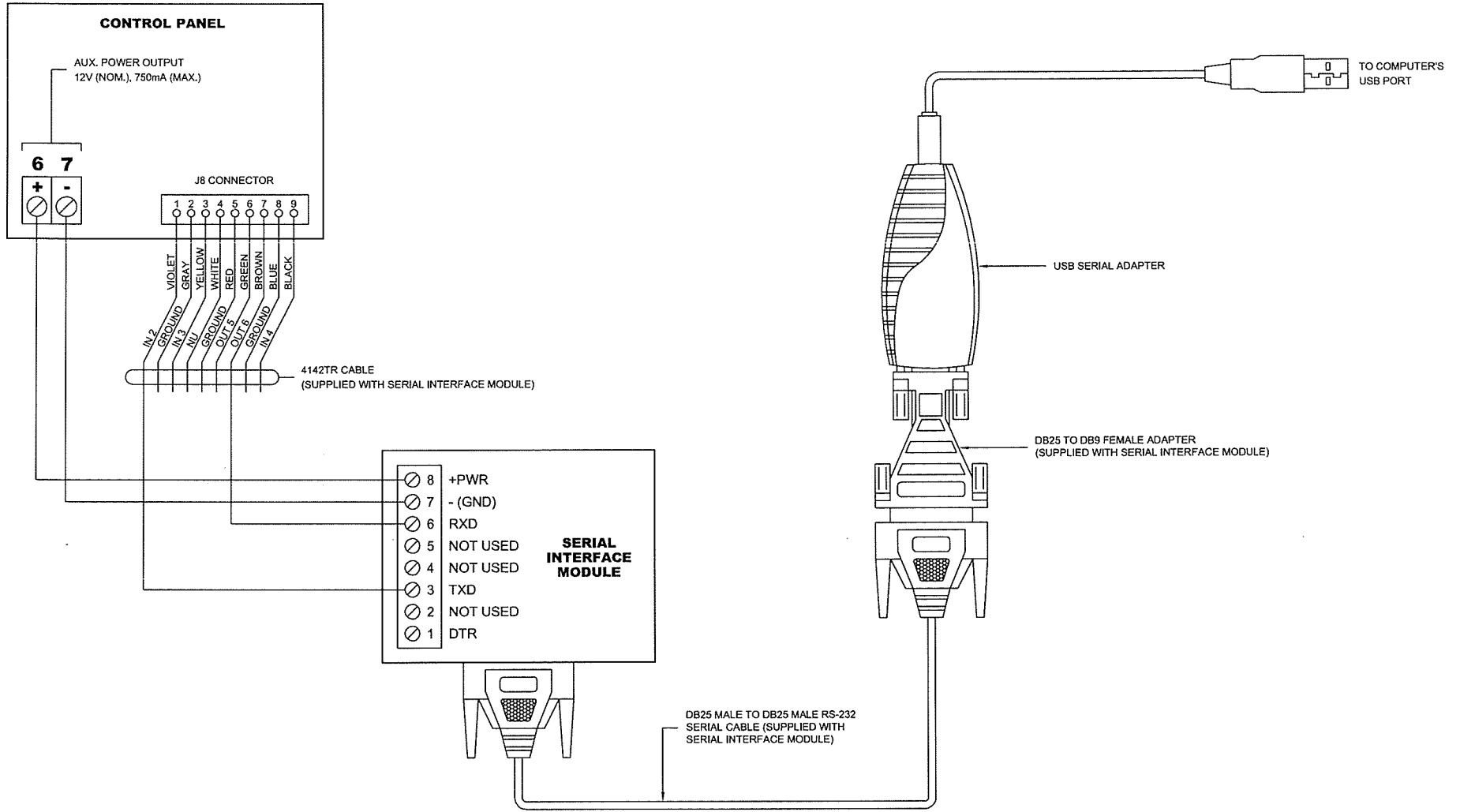

SERIAL INTERFACE SYSTEM POINT-TO-POINT CONNECTIONS - SIS-1

FOR DIRECT-WIRE DOWNLOADING FROM CONTROL PANEL TO COMPUTER WITH COMPASS DOWNLOADING SOFTWARE INSTALLED

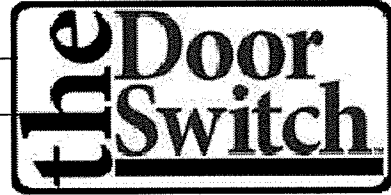

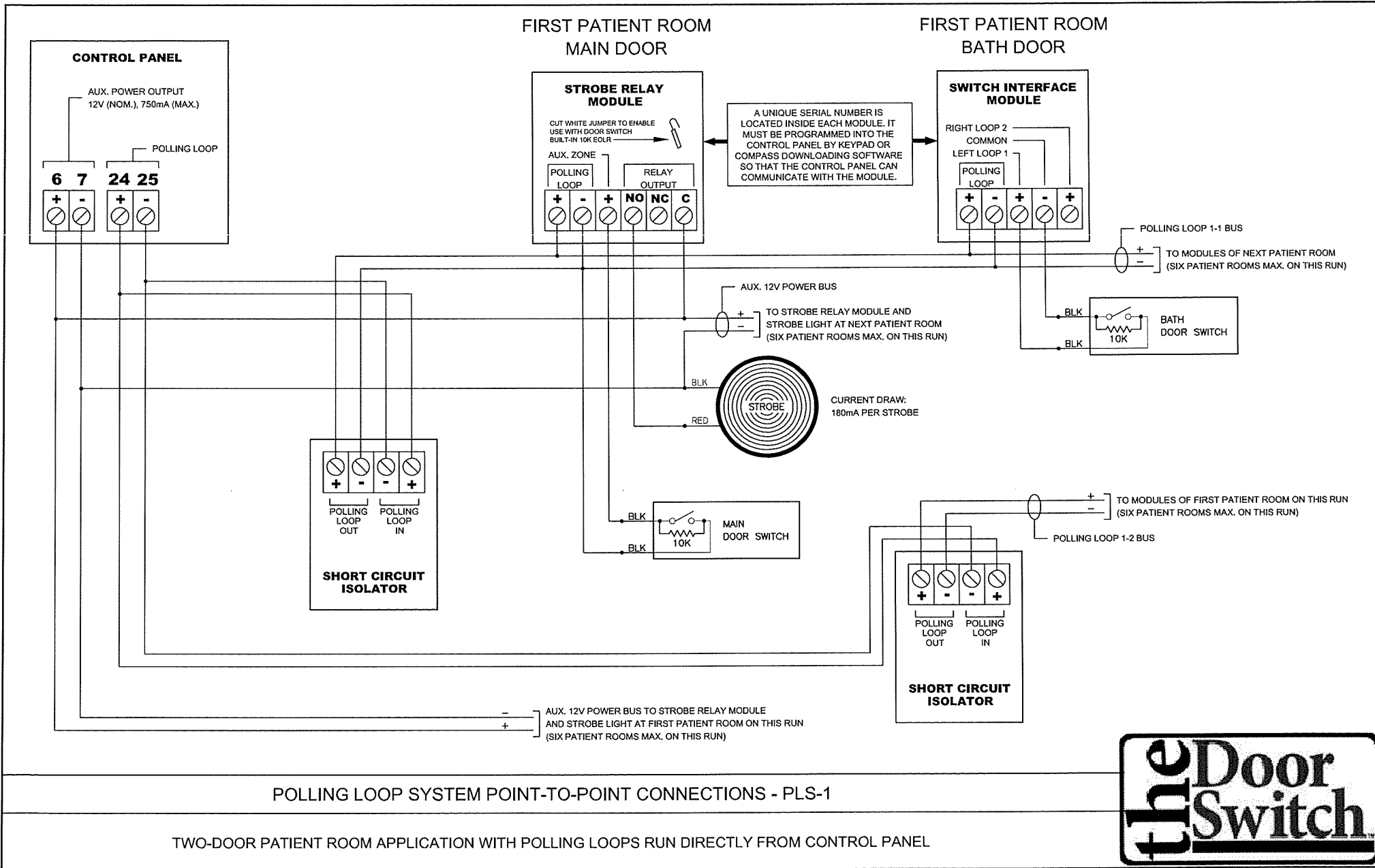

POLLING LOOP SYSTEM POINT-TO-POINT CONNECTIONS - PLS-1

TWO-DOOR PATIENT ROOM APPLICATION WITH POLLING LOOPS RUN DIRECTLY FROM CONTROL PANEL

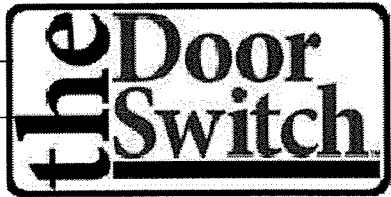

FIRST PATIENT ROOM
MAIN DOOR

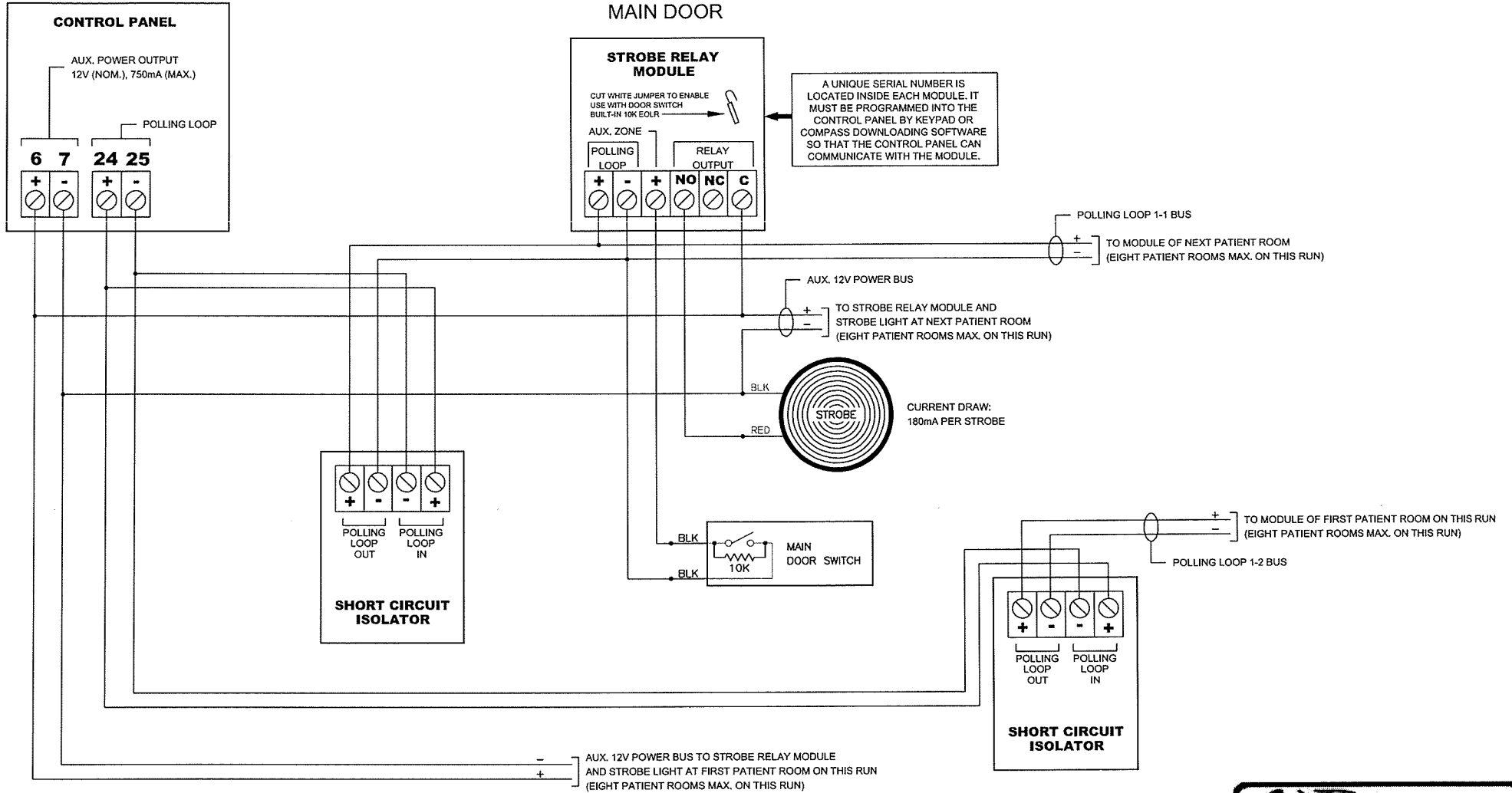

POLLING LOOP SYSTEM POINT-TO-POINT CONNECTIONS - PLS-2

SINGLE DOOR PATIENT ROOM APPLICATION WITH POLLING LOOPS RUN DIRECTLY FROM CONTROL PANEL

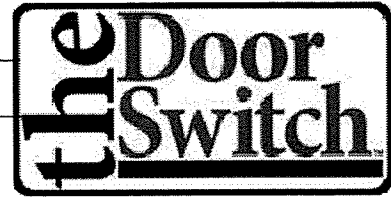

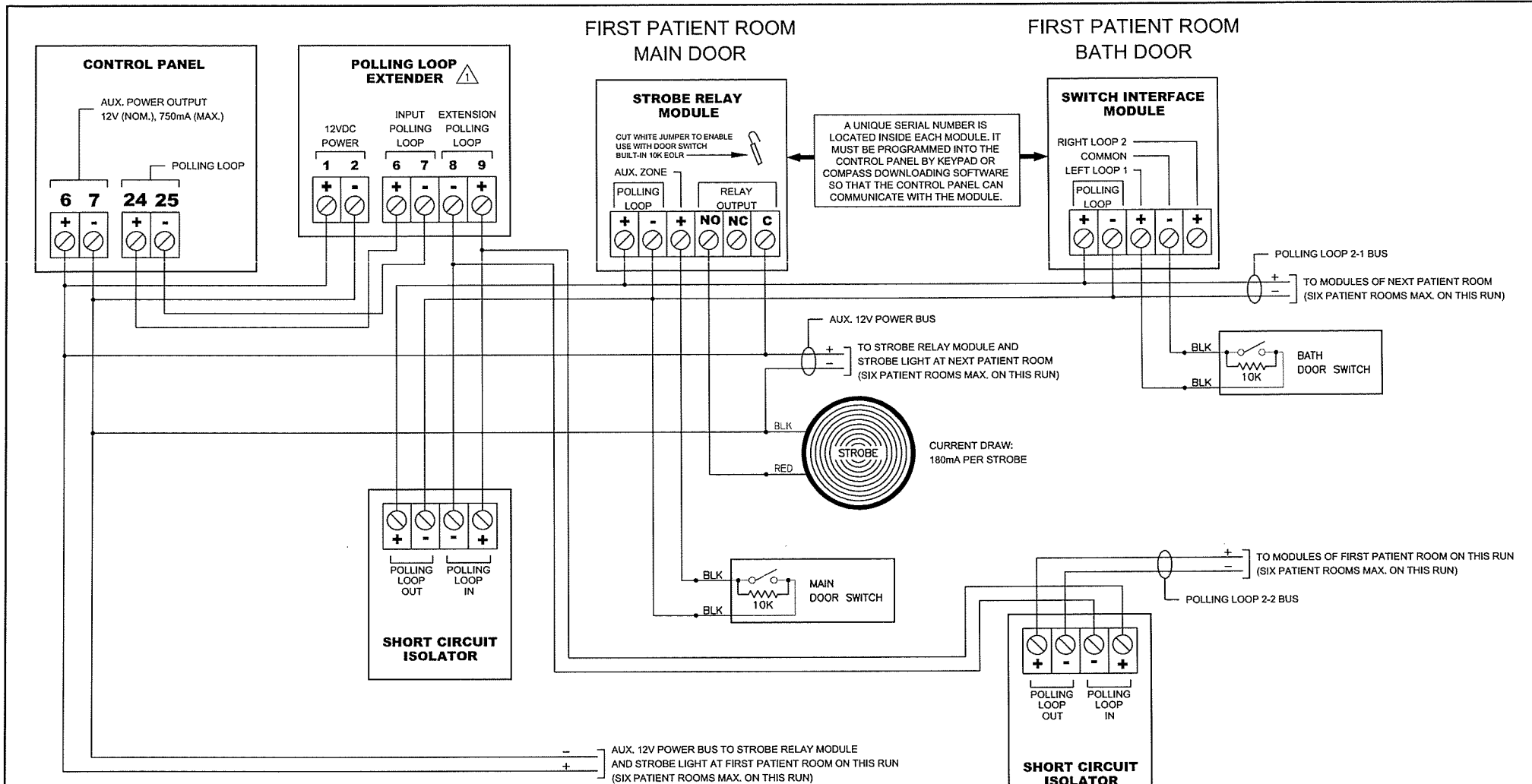

NOTES:
⚠ A MAXIMUM OF EIGHT POLLING LOOP EXTENDERS CAN BE WIRED IN PARALLEL ACROSS THE CONTROL PANEL'S POLLING LOOP OUTPUT.

POLLING LOOP SYSTEM POINT-TO-POINT CONNECTIONS - PLS-3

TWO-DOOR PATIENT ROOM APPLICATION WITH POLLING LOOPS RUN FROM POLLING LOOP EXTENDER
USE EXTENDER WHEN ADDITIONAL POLLING LOOP CURRENT IS REQUIRED (128mA MAX. PER POLLING LOOP EXTENDER)

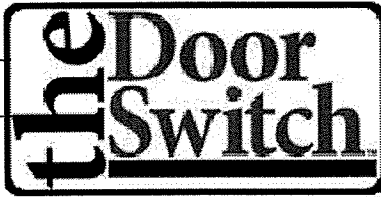

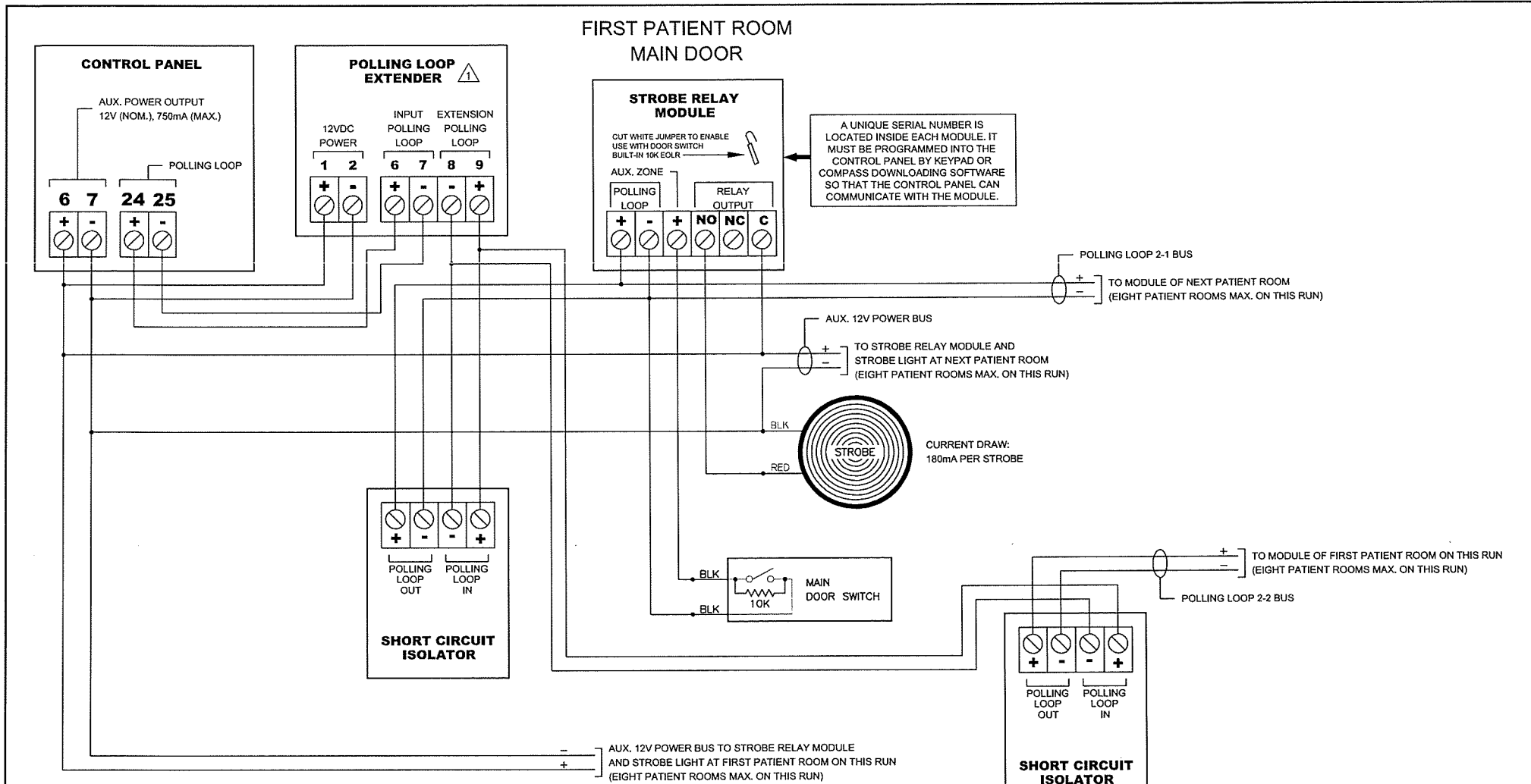

POLLING LOOP SYSTEM POINT-TO-POINT CONNECTIONS - PLS-4

SINGLE DOOR PATIENT ROOM APPLICATION WITH POLLING LOOPS RUN FROM POLLING LOOP EXTENDER
 USE EXTENDER WHEN ADDITIONAL POLLING LOOP CURRENT IS REQUIRED (128mA MAX. PER POLLING LOOP EXTENDER)



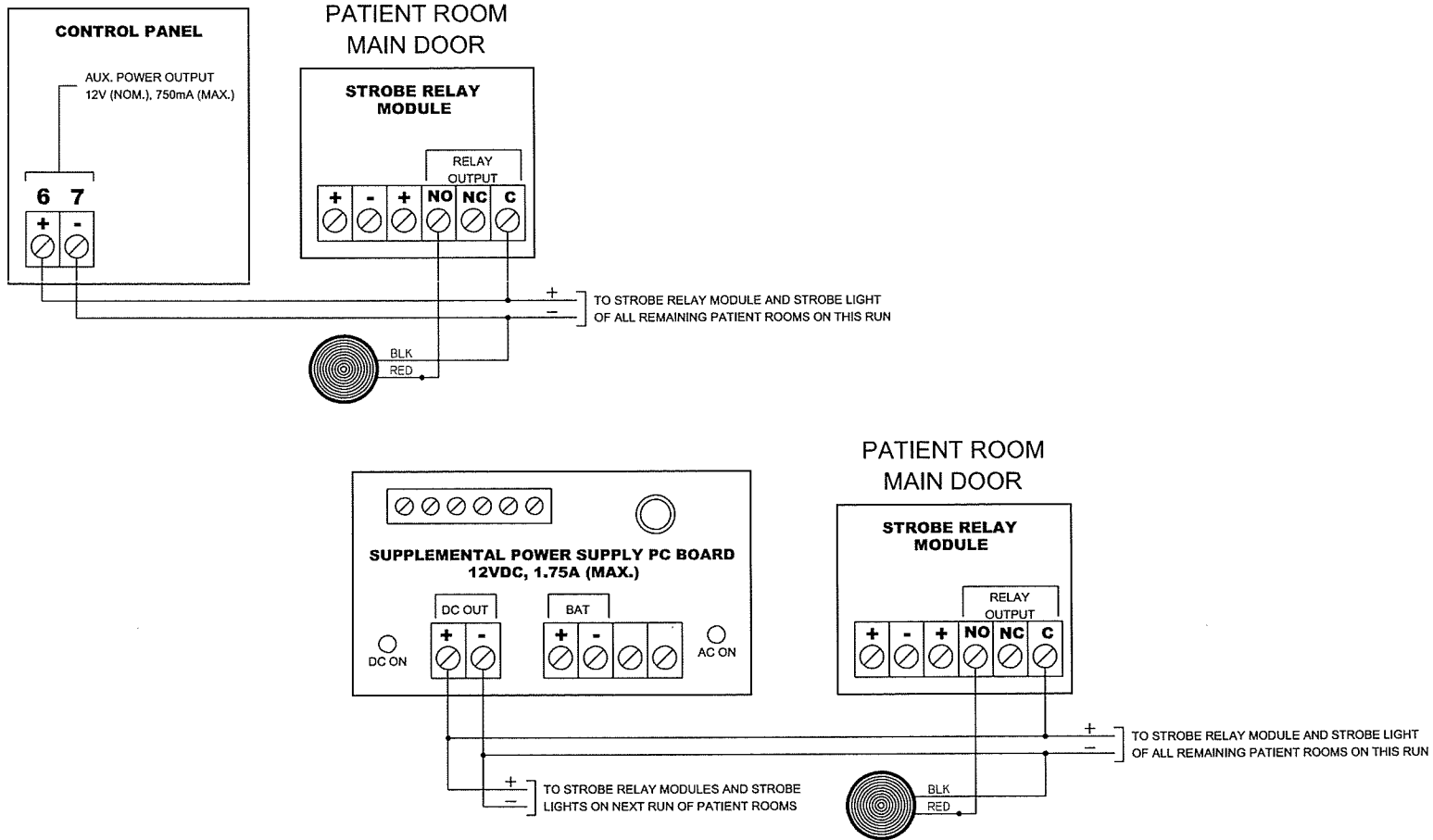

NOTES:

- 1.) THE SUPPLEMENTAL POWER SUPPLY CAN POWER OTHER SYSTEM DEVICES IN COMBINATION WITH THE STROBE LIGHTS, INCLUDING POLLING LOOP EXTENDERS, SUPERVISED NOTIFICATION MODULES, KEYPADS AND PANEL LINKING MODULES.
- 2.) MORE THAN ONE SUPPLEMENTAL POWER SUPPLY MAY BE REQUIRED DEPENDING ON THE NUMBER OF DEVICES USED IN THE SYSTEM AS DETERMINED BY THE NUMBER OF PATIENT ROOMS WITHIN THE FACILITY.

POLLING LOOP SYSTEM POINT-TO-POINT CONNECTIONS - PLS-5

STROBE LIGHT POWER DISTRIBUTION FROM CONTROL PANEL AND SUPPLEMENTAL POWER SUPPLY



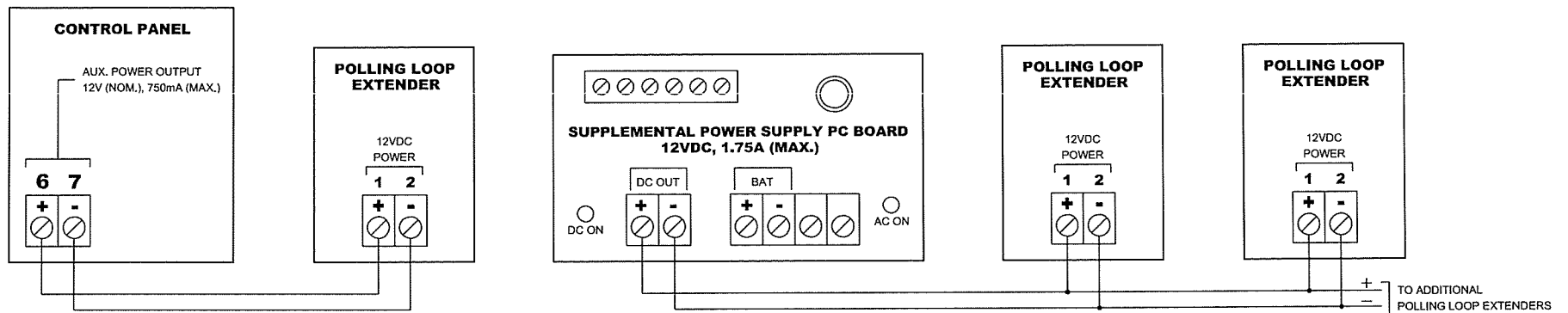

NOTES:

- 1.) THE SUPPLEMENTAL POWER SUPPLY CAN POWER OTHER SYSTEM DEVICES IN COMBINATION WITH THE POLLING LOOP EXTENDERS, INCLUDING STROBE LIGHTS, SUPERVISED NOTIFICATION MODULES, KEYPADS AND PANEL LINKING MODULES.
- 2.) MORE THAN ONE SUPPLEMENTAL POWER SUPPLY MAY BE REQUIRED DEPENDING ON THE NUMBER OF DEVICES USED IN THE SYSTEM AS DETERMINED BY THE NUMBER OF PATIENT ROOMS WITHIN THE FACILITY.

POLLING LOOP SYSTEM POINT-TO-POINT CONNECTIONS - PLS-6

POLLING LOOP EXTENDER POWER DISTRIBUTION FROM CONTROL PANEL AND SUPPLEMENTAL POWER SUPPLY

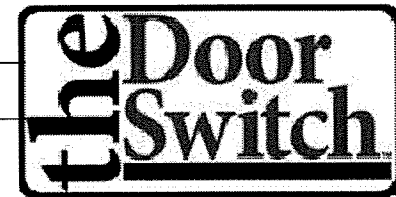

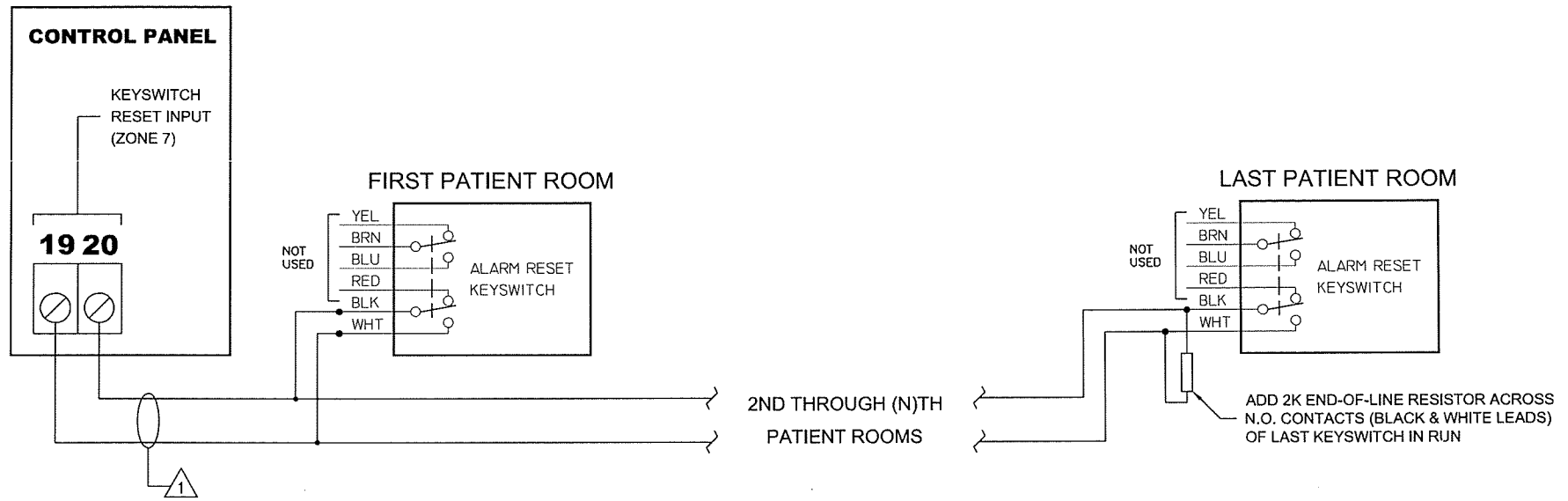

NOTES:

- 1 ALARM RESET KEYSWITCHES MUST BE WIRED IN PARALLEL ACROSS A CONTINUOUS TWO-CONDUCTOR RUN FROM THE FIRST KEYSWITCH TO THE LAST (SHOWN ABOVE). DO NOT MAKE MULTIPLE RUNS (AS IN A STAR CONFIGURATION) ORIGINATING FROM THE CONTROL PANEL.

ALARM RESET KEYSWITCH LOOP POINT-TO-POINT CONNECTIONS - ARK-1

ONE KEYSWITCH STATIONED NEAR EACH PATIENT ROOM

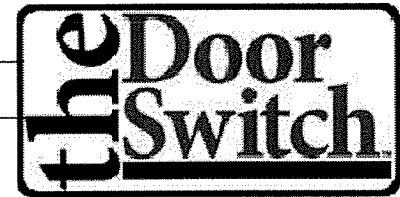

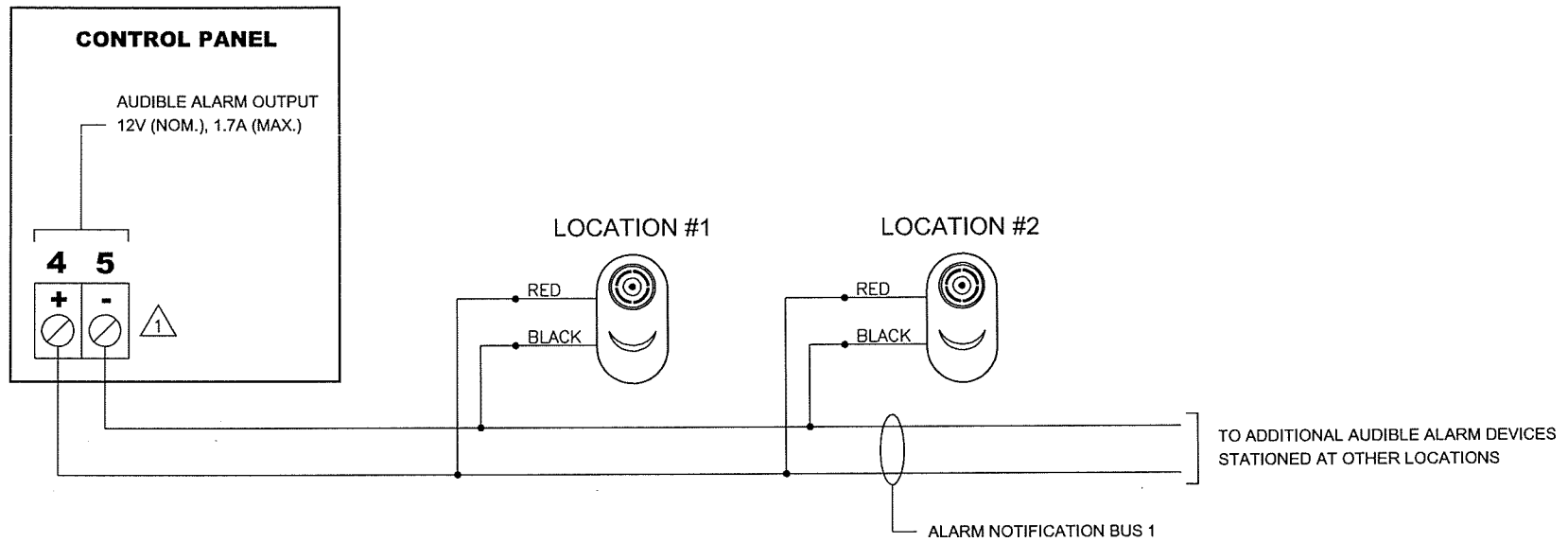

NOTES:

- ⚠ THIS OUTPUT SWITCHES 12VDC POWER TO AUDIBLE ALARM DEVICES DURING A DOOR SWITCH ALARM CONDITION. NO END-OF-LINE RESISTORS ARE REQUIRED. ALARM OUTPUT SUPERVISION IS ENABLED THROUGH PROGRAMMING (SEE THE CONTROL PANEL'S INSTALLATION INSTRUCTIONS FOR DETAILS).

AUDIBLE ALARM DEVICE LOOP POINT-TO-POINT CONNECTIONS - AAD-1

SINGLE, OR MULTIPLE ALARM NOTIFICATION (IN UNISON) WITHIN VARIOUS LOCATIONS OF A FACILITY (FLOOR, WING, ETC.)

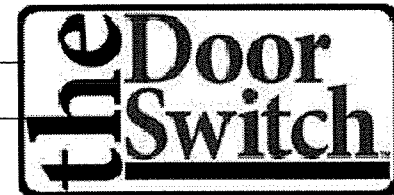

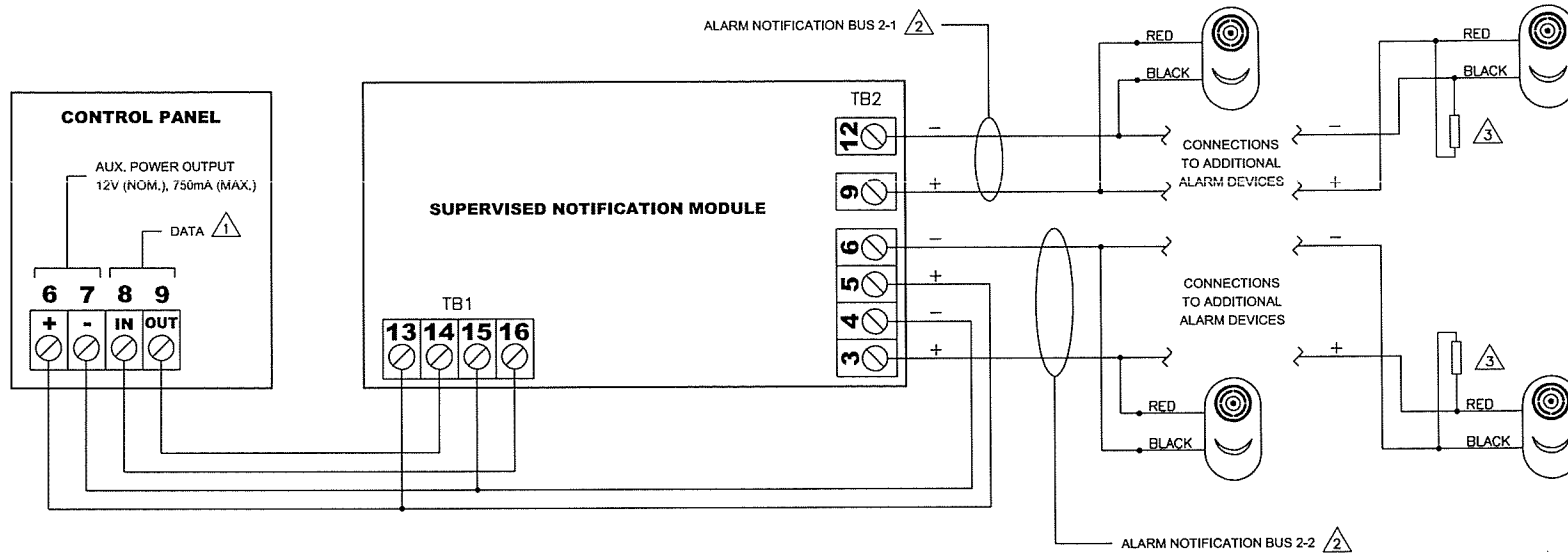

NOTES:

- 1 THE MAXIMUM NUMBER OF SUPERVISED NOTIFICATION MODULES THAT CAN BE WIRED ACROSS THE CONTROL PANEL'S DATA IN/OUT BUS IS 15. AVAILABLE ADDRESSES FOR SELECTION INSIDE THE MODULE ARE 01 THROUGH 15 (SEE THE CONTROL PANEL'S INSTALLATION INSTRUCTIONS FOR DETAILS).
- 2 BOTH ALARM OUTPUTS CAN BE PROGRAMMED TO ACTIVATE IN UNISON WITH EACH OTHER, INCLUDING THE CONTROL PANEL'S ALARM OUTPUT. ALTERNATIVELY, BOTH OUTPUTS CAN BE PROGRAMMED TO ACTIVATE INDEPENDENTLY OF EACH OTHER, INCLUDING THE CONTROL PANEL'S ALARM OUTPUT (SEE THE CONTROL PANEL'S PROGRAMMING GUIDE FOR DETAILS).
- 3 ADD 2K END-OF-LINE RESISTOR ACROSS RED AND BLACK LEADS OF LAST AUDIBLE ALARM IN RUN.

SUPERVISED NOTIFICATION SYSTEM POINT-TO-POINT CONNECTIONS - SNS-1

NOTIFICATION MODULES AND AUDIBLE ALARMS POWERED FROM CONTROL PANEL



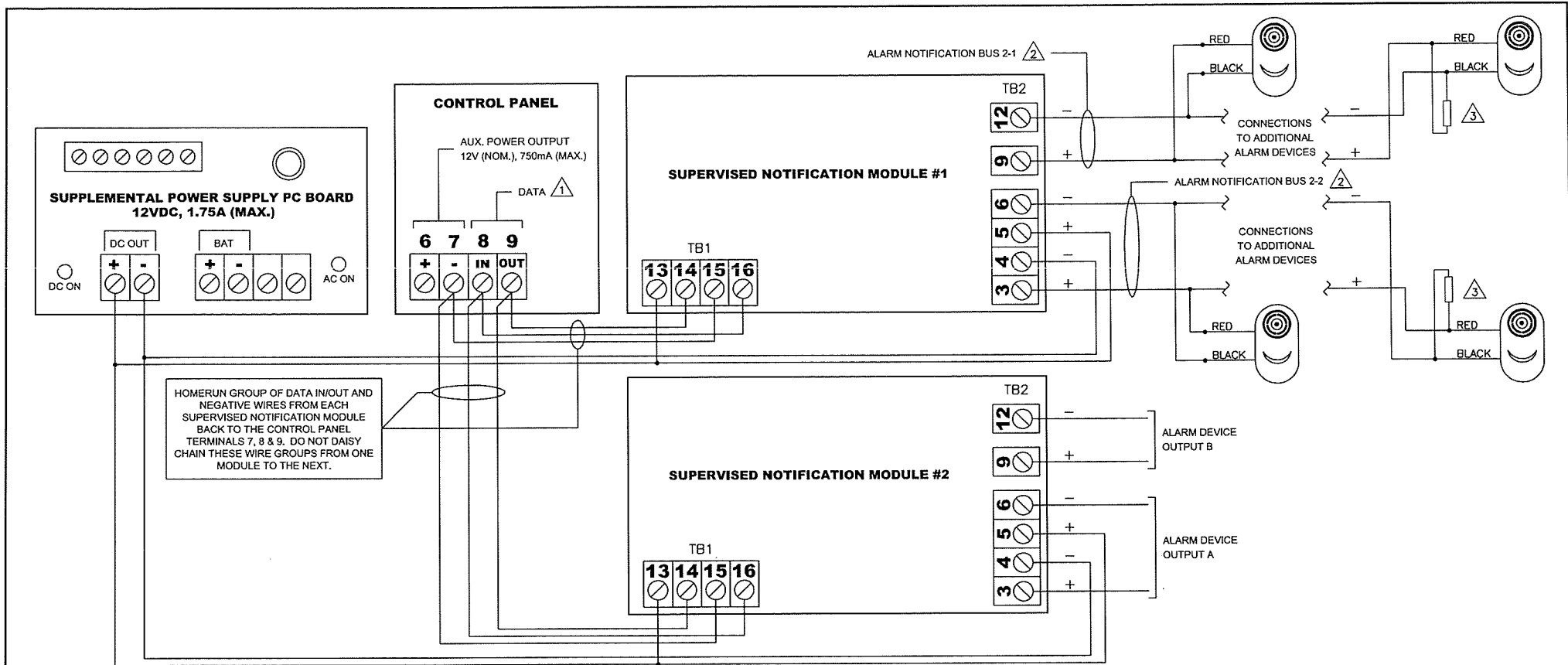

NOTES:

- 1 THE MAXIMUM NUMBER OF SUPERVISED NOTIFICATION MODULES THAT CAN BE WIRED ACROSS THE CONTROL PANEL'S DATA IN/OUT BUS IS 15. AVAILABLE ADDRESSES FOR SELECTION INSIDE THE MODULE ARE 01 THROUGH 15 (SEE THE CONTROL PANEL'S INSTALLATION INSTRUCTIONS FOR DETAILS).
- 2 BOTH ALARM OUTPUTS CAN BE PROGRAMMED TO ACTIVATE IN UNISON WITH EACH OTHER, INCLUDING THE CONTROL PANEL'S ALARM OUTPUT. ALTERNATIVELY, BOTH OUTPUTS CAN BE PROGRAMMED TO ACTIVATE INDEPENDENTLY OF EACH OTHER, INCLUDING THE CONTROL PANEL'S ALARM OUTPUT (SEE THE CONTROL PANEL'S PROGRAMMING GUIDE FOR DETAILS).
- 3 ADD 2K END-OF-LINE RESISTOR ACROSS RED AND BLACK LEADS OF LAST AUDIBLE ALARM IN RUN.

SUPERVISED NOTIFICATION SYSTEM POINT-TO-POINT CONNECTIONS - SNS-2

NOTIFICATION MODULES AND AUDIBLE ALARMS POWERED FROM A SUPPLEMENTAL POWER SUPPLY



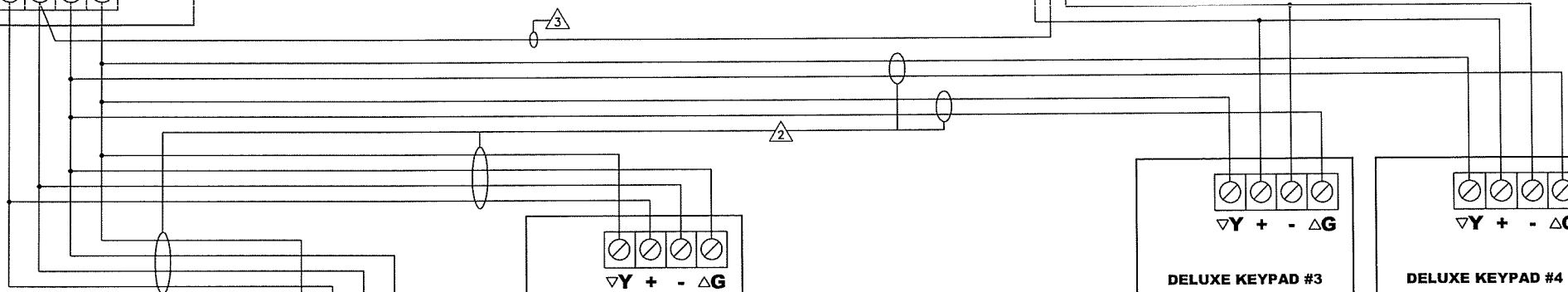
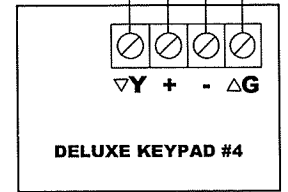
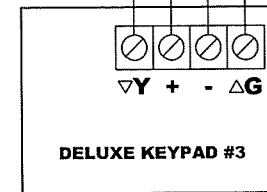
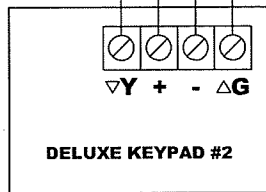
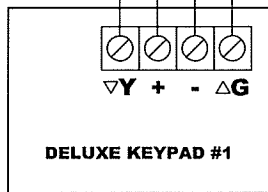
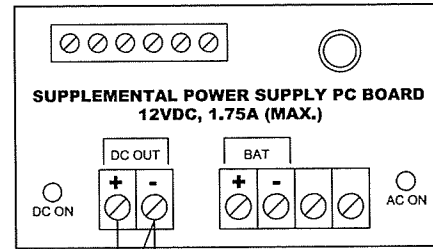
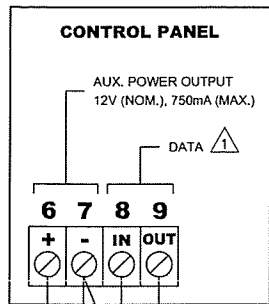

NOTES:

- ⚠️ THE MAXIMUM NUMBER OF KEYPADS THAT CAN BE WIRED ACROSS THE CONTROL PANEL'S DATA IN/OUT BUS IS 31 (AVAILABLE ADDRESSES: 00-30). SEE THE KEYPAD'S INSTALLATION INSTRUCTIONS FOR PROGRAMMING ADDRESSES.
- ⚠️ HOMERUN BACK TO THE CONTROL PANEL THE DATA AND POWER WIRES FROM EACH KEYPAD THAT IS POWERED BY THE CONTROL PANEL. HOMERUN BACK TO THE CONTROL PANEL THE DATA WIRES FROM EACH KEYPAD THAT IS POWERED BY THE SUPPLEMENTAL POWER SUPPLY AS SHOWN IN THE ABOVE ILLUSTRATION. DO NOT DAISY CHAIN THESE WIRE GROUPS FROM ONE KEYPAD TO THE NEXT.
- ⚠️ IN ORDER TO PROVIDE A RETURN PATH FROM THE DATA IN/OUT TERMINALS OF EACH KEYPAD POWERED BY THE SUPPLEMENTAL POWER SUPPLY, A WIRE MUST BE CONNECTED BETWEEN TERMINAL 7 OF THE CONTROL PANEL AND THE NEGATIVE TERMINAL OF THE SUPPLEMENTAL POWER SUPPLY.

KEYPAD SYSTEM POINT-TO-POINT CONNECTIONS - KPD-1

KEYPADS POWERED FROM CONTROL PANEL AND A SUPPLEMENTAL POWER SUPPLY

