



Life More Secure.

FOR INSTALLATION AND
PRODUCT INFORMATION,
CALL OUR TOLL-FREE NUMBER
MONDAY-FRIDAY 8:00AM - 5:00PM CST:

1-877-998-5625

OR VISIT OUR WEBSITE AT:

WWW.THEDOORSWITCH.COM

The Door Switch™ is a patented design.

U.S. Patent No. RE42,991

U.S. Patent No. RE44,039

DOORWAY COMPONENT INSTALLATION SHEETS
(RETROFITTING DOORWAY HAVING BUTT HINGES)

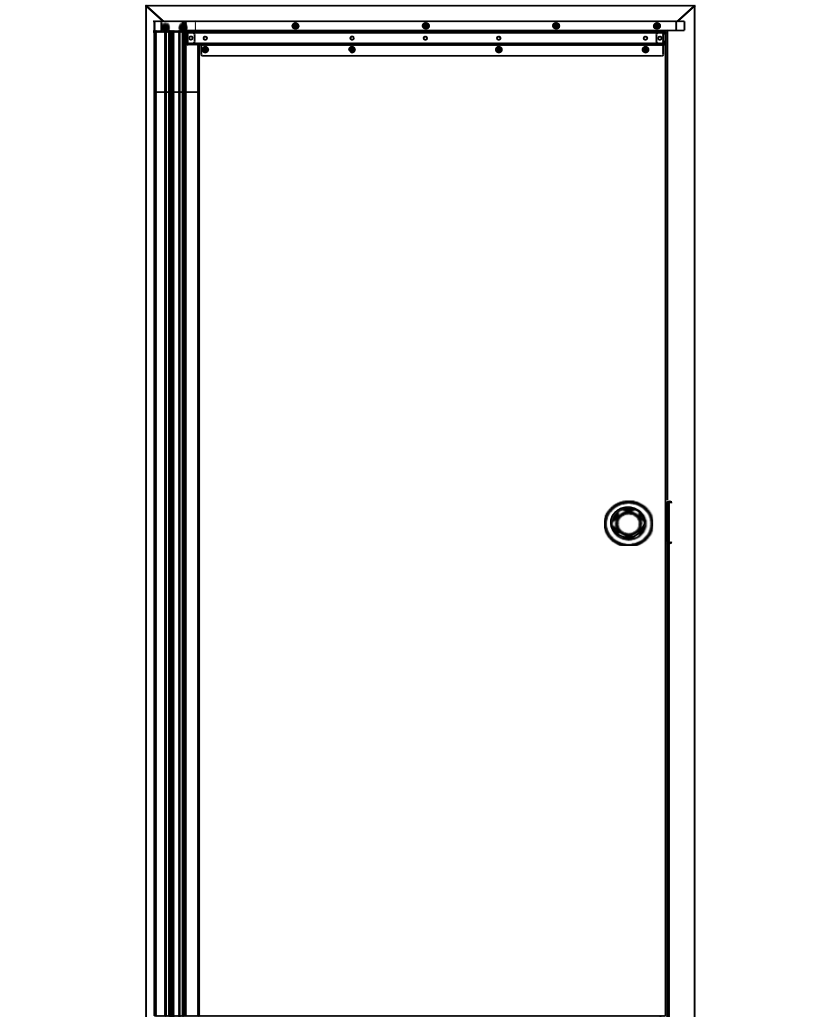

Note: Frame reinforcement: None required for doors up to 200 lbs. For doors more than 200 lbs., 16-gauge channel required.

Doorway Preparation

1. Verify there is a 1-1/2" minimum frame face.
2. Verify the door latch enters the frame strike when there is 1/8" minimum clearance between the frame head rabbet and the top of the door.
3. Verify there is 1/8" minimum clearance between the hinge side frame jamb and the side of the door.
4. Measure the distance between the frame head rabbet and the bottom of the door. ***This measurement minus the length of the electrified hinge will be the length of the mechanical hinge.***
5. Remove the door and butt hinges from the frame. Remove the butt hinges from the door and discard.
6. Drill a 1/2" diameter wire access hole through the frame at the top butt hinge location for making the electrical connections between the electrified hinge frame leaf wires and The Door Switch System module wires.

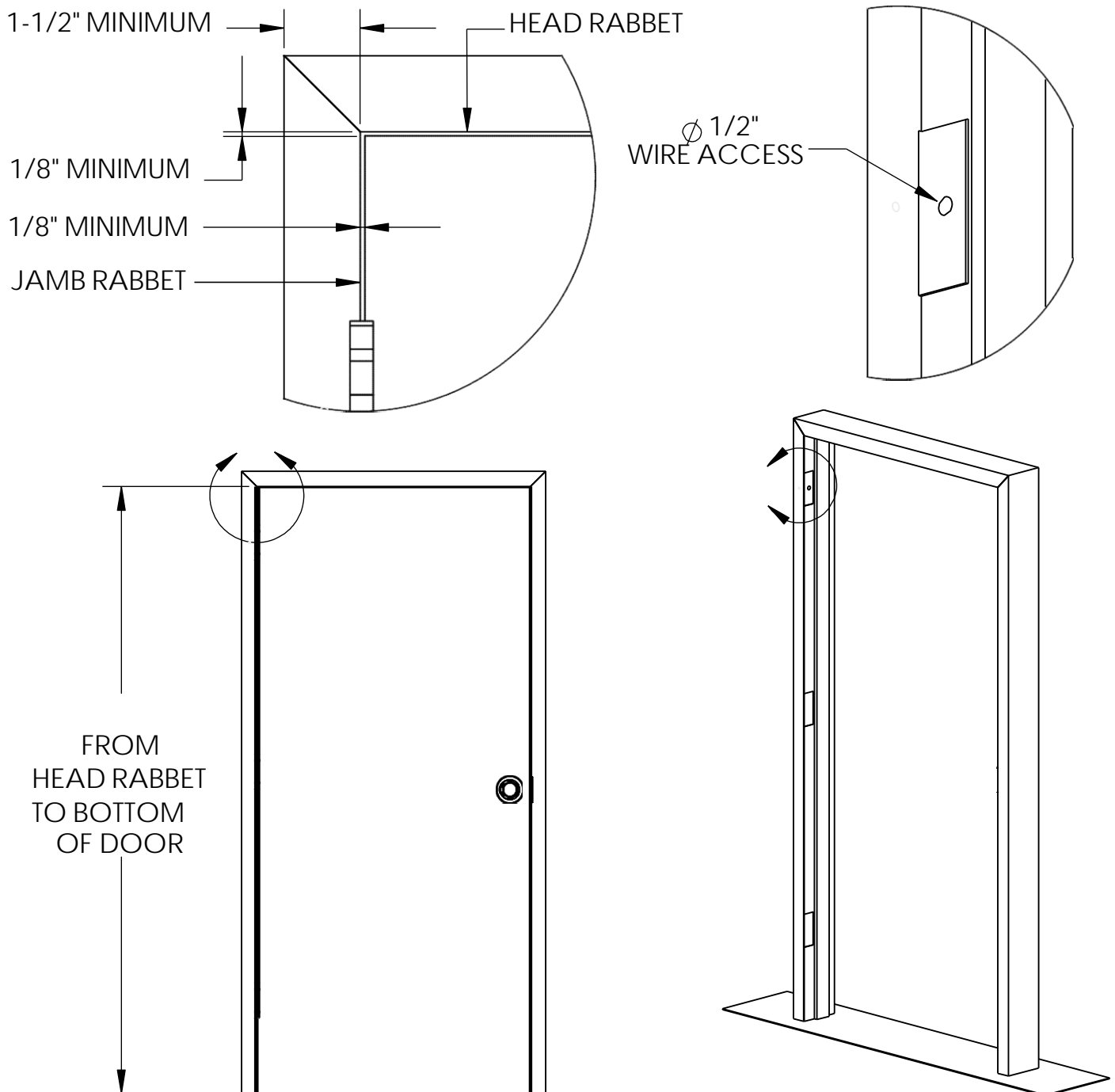

Header Installation

1. Mark the mounting hole locations using the header as a guide. Locate the hinge side of the header 1-1/2" from the frame jamb rabbet and align the bottom of the header with the frame head rabbet.
2. Center punch, drill, and tap the mounting holes into the frame face for a 1/4"-20 thread. (Recommended drill size is .201" diameter, #7 drill bit.) **Accurate location is important for proper installation.**
3. Attach the header to the frame using the 1/4"-20 tamper-resistant screws provided. Mini header must be kept flush with full length header. Header must be installed tight against the door frame (no gaps).

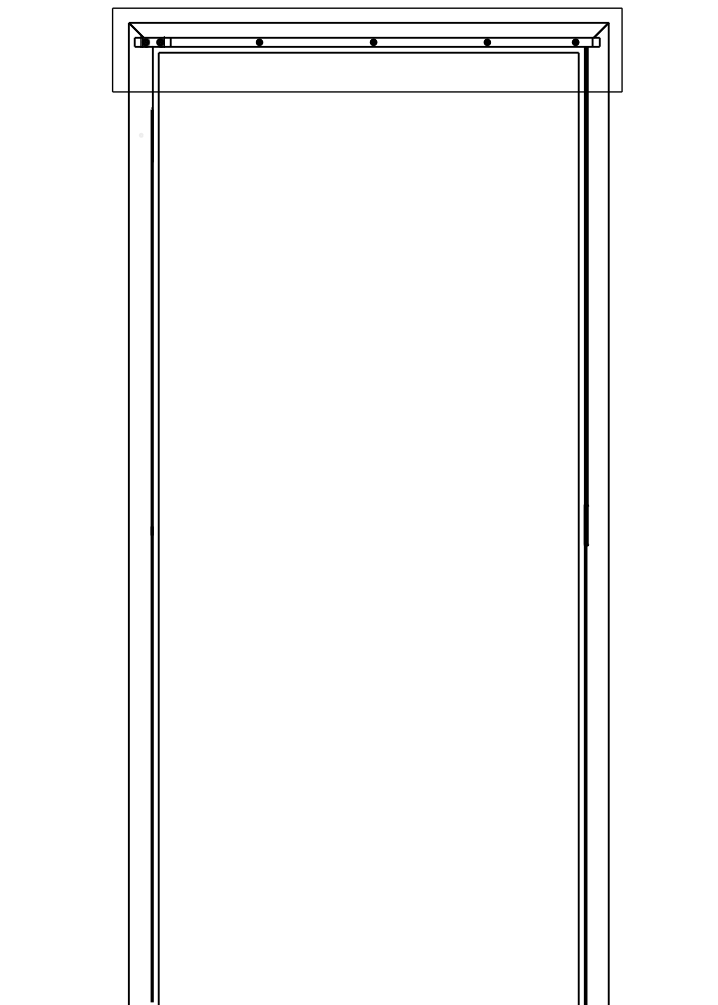
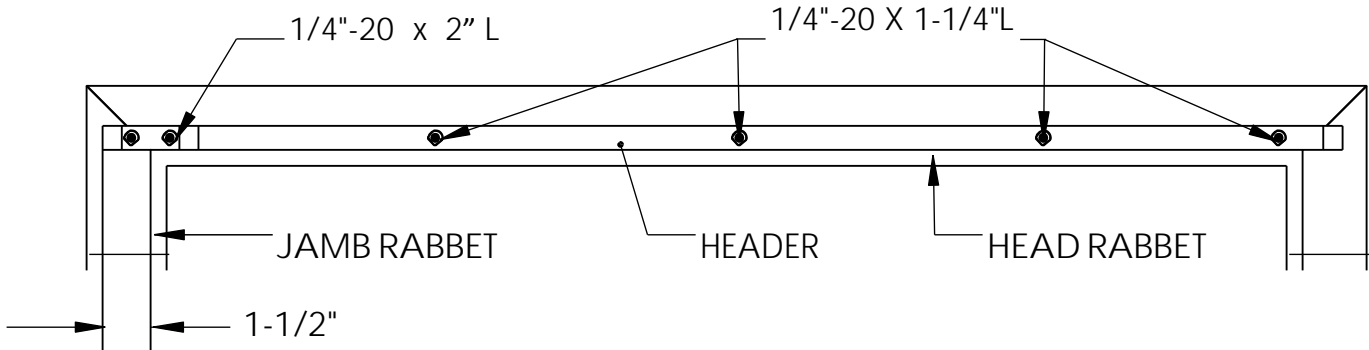

Electrified and Mechanical Hinge Installation

1. If necessary, drill $\frac{1}{4}$ " holes in electrified section of hinge. Two holes required on door leaf and three holes required on frame leaf side.
2. Set the door into the frame using shims or wedges to adjust for $\frac{1}{8}$ " maximum clearances between the frame head and jamb rabbets and the door.
3. Position the switch on the top of the door with the end of the switch even with the edge of the door.
4. Set electrified hinge with the notch around the notch on the switch with the top of the hinge flush ($\frac{1}{32}$ " maximum gap) to the header bar.
5. Mark and center punch the mounting hole locations. **Accurate location is important for proper installation.**
6. Attach the electrified hinge to the frame face using the screws provided.
7. Cut the bottom of the mechanical hinge and covers to the required length.
8. Place the outer edge of the mechanical hinge even with the outer edge of the electrified hinge making sure it is even the entire length.
9. Mark and center punch the mounting hole locations.
10. Attach the mechanical hinge to the frame face using the screws provided.
11. Insert the electrified hinge frame leaf wires through the wire access hole and make the electrical connections to The Door Switch System module.

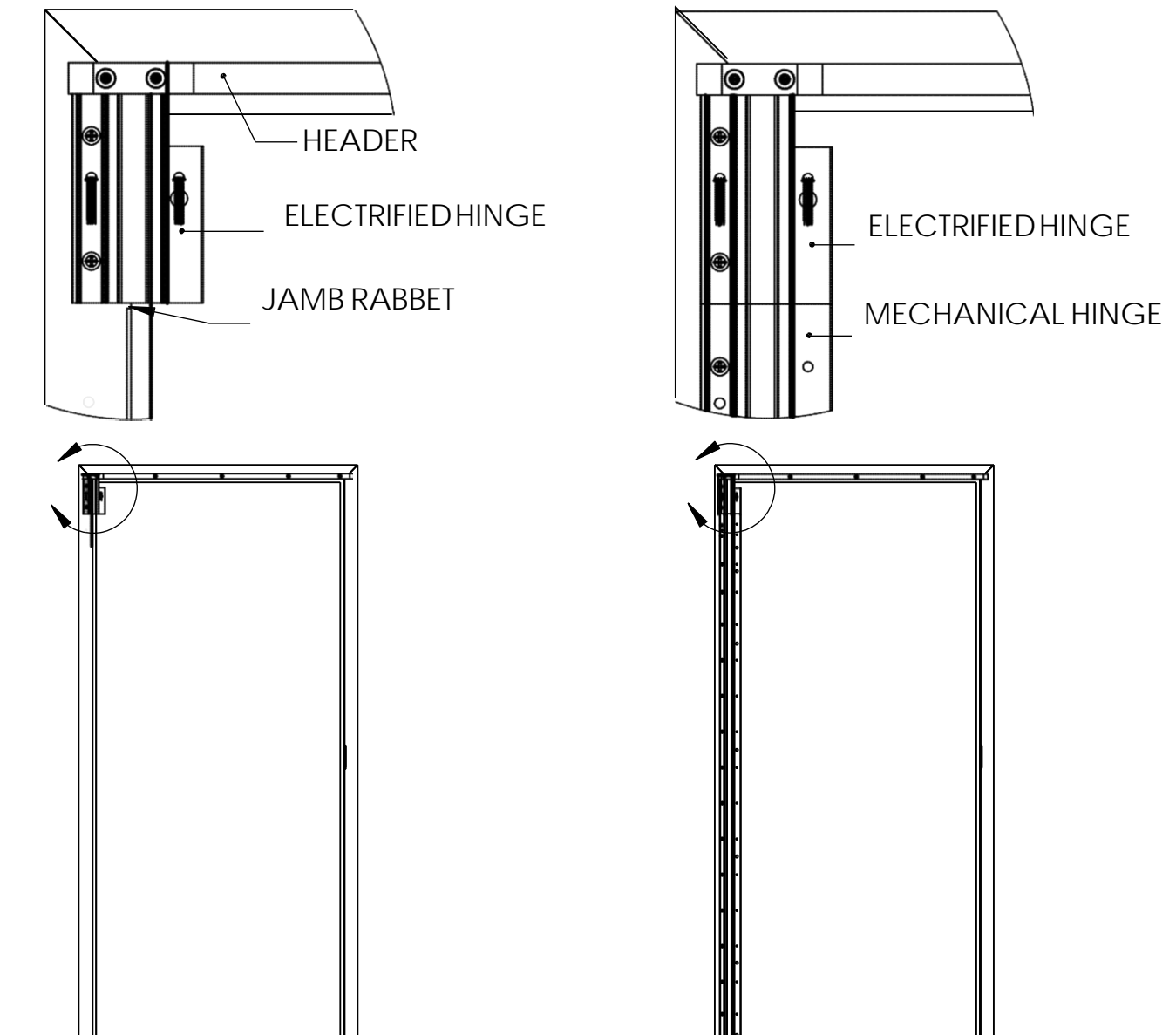

Door Installation

1. Reference mechanical hinge installation instructions.
2. With the door held securely in place, rotate the hinge door leaf's into position on the face of the door.
3. Mark, center punch, and drill the 3/8" diameter mounting holes completely through the door for the mechanical hinge. **Accurate location is important for proper installation.** Rotate the hinge leaf's out of the way when drilling through the door.
4. Attach mechanical hinge to the door using the sexbolts provided with the mechanical hinge.
5. Remove all shims or wedges and check the door for proper swing and clearances.
6. Attach electrified hinge to door using wood or self-drilling screws.

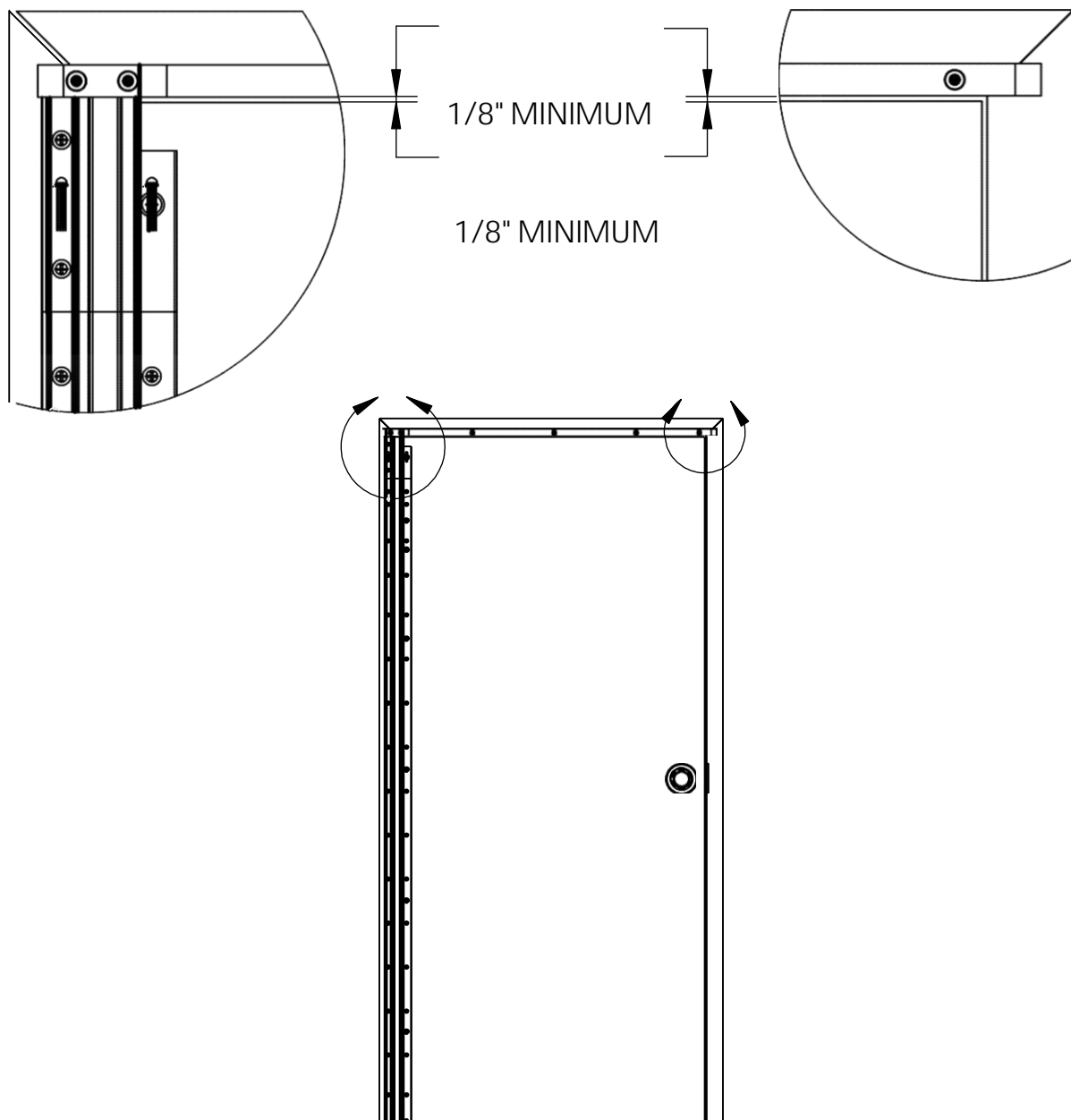

Switch Installation

1. Mark the mounting hole locations using the switch as a guide. Locate the switch flush (1/32" maximum gap) to the hinge and the switch actuator 1/8" maximum to the header.
2. Center punch and drill the 3/8" diameter mounting holes completely through the door. **Accurate location is important for proper installation.**
3. Attach the switch to the door using the 1/4"-20 tamper-resistant screws and sexbolts provided.
4. Verify there is 1/8" maximum clearance between the switch actuator and the header.
5. Make the electrical connections between the electrified hinge door leaf wires and the switch wires. **Combine the same color wires as used when connecting the electrified hinge frame leaf wires to The Door Switch System module.**

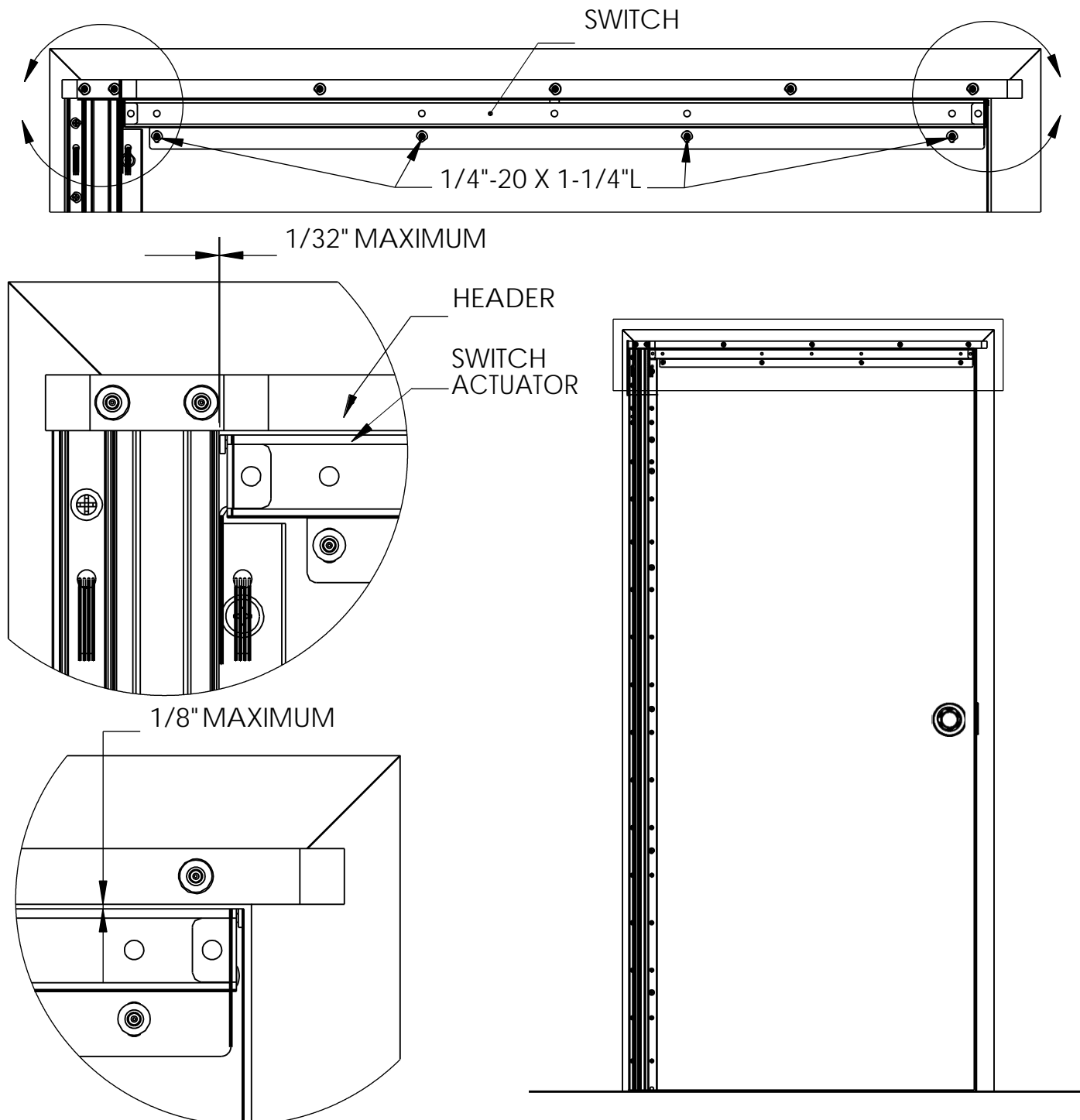

Complete the Installation

1. Verify the switch is operating properly with The Door Switch System. **Moving the switch actuator closer to the header will improve the switch operation.**
2. Install hinge plates, supplied by others, to cover locations of the butt hinges.
3. Reference the mechanical hinge installation instructions for attaching the Snap-on moldings for both the electrical and mechanical hinges. **Install the electrical hinge moldings first.**

